

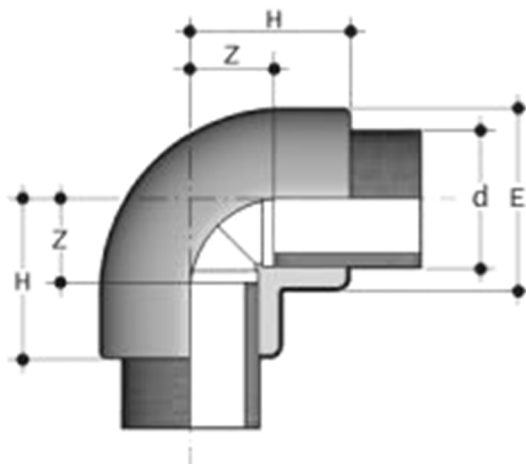

Gomito 90° PP

Estremità per saldatura nel bicchiere
Codice: DGIM

PP elbow 90°
Ends for socket fusion welding
Code: DGIM



d	E	H	Z	PN	Peso Weight (gr)
20	26	27,5	12,0	10	14
25	32	32,0	16,0	10	23
32	40	37,0	20,0	10	37
40	50	42,5	22,0	10	64
50	61	51,0	27,5	10	105
63	76	61,0	33,5	10	180
75	91	73,0	42,0	10	300
90	108	84,5	49,0	10	455
110	130	100,5	59,0	10	815

- Attacchi in accordo alle seguenti normative:
DIN 16962, UNIPLAST 383 accoppiabili con tubi secondo le norme ISO DIS 3609, DIN 8077, UNI 8318, BS 4991, ISO DIS 15494

- Coupling comply with the following standards:
DIN 16962, UNIPLAST 383 coupling to pipes complying with ISO DIS 3609, DIN 8077, UNI 8318, BS 4991, ISO DIS 15494