



Calotta PP-H

- Codice prodotto: CBM
- Estremità per saldatura testa a testa
- Attacchi in accordo con le seguenti norme:
DIN 16962, accoppiabili con tubi secondo le norme EN ISO 15494, DIN 8077-8078, UNI 8318.

PP-H end cap

- Product code: CBM
- Ends for butt fusion welding
- Coupling according with following standards:
DIN 16962, coupling to pipes complying with EN ISO 15494,
DIN 8077-8078, UNI 8318.

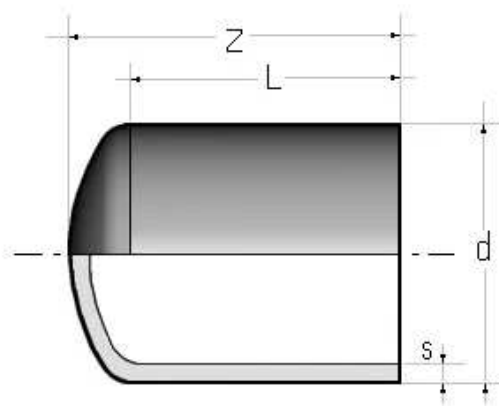

d	SDR 17,6 - S 8,3 - PN 6				SDR 11 - S 5 - PN 10			
	Z	L	s	Peso Weight (g)	Z	L	s	Peso Weight (g)
20	-	-	-	-	45	35	1,9	10
25	-	-	-	-	52	40	2,3	10
32	-	-	-	-	58	44	2,9	20
40	-	-	-	-	67	50	3,7	30
50	-	-	-	-	75	55	4,6	50
63	-	-	-	-	85	62	5,8	90
75	-	-	-	-	95	63	6,8	130
90	-	-	-	-	110	79	8,2	230
110	-	-	-	-	127	88	10,0	400
125	124	95	7,1	360	130	94	11,4	520
140	136	110	8,0	485	142	99	12,7	695
160	161	121	9,1	735	162	109	14,6	1010
180	167	134	10,2	990	191	141	16,4	1375
200	184	140	11,4	1310	181	127	18,2	1860
225	200	160	12,8	1790	205	129	20,5	2680
250	45	-	14,2	1520	50	-	22,7	1840
280	45	-	15,9	2070	55	-	25,4	2560
315	50	-	17,9	2940	60	-	28,6	3600
355	55	-	20,1	4170	65	-	32,2	5040
400	60	-	22,7	5960	70	-	36,3	7240