



Collare d'appoggio PP-H

- Codice prodotto: QBM
- Estremità per saldatura testa a testa
- Attacchi in accordo con le seguenti norme:
DIN 16962, accoppiabili con tubi secondo le norme EN ISO 15494, DIN 8077-8078, UNI 8318.



PP-H stub end

- Product code: QBM
- Ends for butt fusion welding
- Coupling according with following standards:
DIN 16962, coupling to pipes complying with EN ISO 15494,
DIN 8077-8078, UNI 8318.

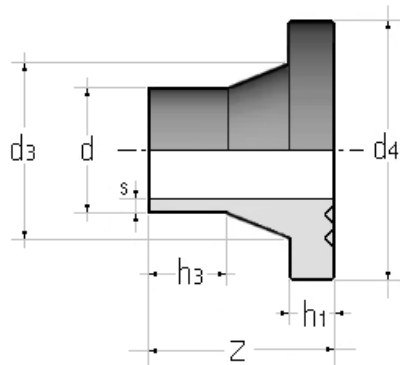

d	d ₃	d ₄	SDR 17,6 - S 8,3 - PN 6					SDR 11 - S 5 - PN 10				
			h ₁	h ₃	Z	s	Peso Weight (g)	h ₁	h ₃	Z	s	Peso Weight (g)
20	27	46	-	-	-	-	-	8	29	52	1,9	18
25	32	59	-	-	-	-	-	10	27	52	2,3	33
32	40	68	-	-	-	-	-	10	26	50	2,9	44
40	49	78	-	-	-	-	-	11	24	52	3,7	65
50	61	89	-	-	-	-	-	12	27	57	4,6	85
63	75	102	14	18	50	3,6	115	14	16	50	5,8	129
75	89	122	16	35	50	4,3	180	16	14	50	6,8	200
90	105	138	17	43	80	5,1	280	17	33	80	8,2	322
110	125	158	18	37	80	6,3	365	18	27	80	10,0	430
125	132	158	18	45	88	7,1	380	25	35	80	11,4	540
140	155	188	18	39	83	8,0	510	25	39	83	12,7	715
160	175	212	18	52	100	9,1	745	25	27	80	14,6	915
180	186	212	20	62	83	10,2	650	30	65	127	16,4	920
200	233	268	24	58	121	11,4	1756	32	50	123	18,2	2160
225	235	268	24	46	100	12,8	1290	32	38	100	20,5	1780
250	285	320	25	61	120	14,2	2170	35	51	121	22,7	2915
280	291	320	25	65	100	15,9	1825	35	69	119	25,4	2900
315	335	370	25	35	110	17,9	2525	35	86	186	28,6	5525
355	373	430	30	99	184	20,1	5400	40	90	180	32,2	7730
400	427	482	33	98	195	22,7	7120	46	95	195	36,3	10485