



VALVOLA MANUALE A SFERA MANUAL BALL VALVE



Caratteristiche

- Valvola bighiera **serie industria** a due vie con corpo in PVC e attacchi bocchettonati femmina per incollaggio conformi alla normativa EN ISO 1452
- Gamma dimensionale da DN 10 mm a DN 100 mm
- Guarnizioni di tenuta in EPDM (standard) o FPM (a richiesta)
- Resistenza pressioni di esercizio:
 - dal DN 10 al DN 50: 16 bar con acqua a 20 °C
 - dal DN 65 al DN 100: 10 bar con acqua a 20 °C
- Bidirezionale
- Elevata manovrabilità (bassa coppia di manovra)
- Estrema sicurezza di funzionamento garantita dal collaudo al 100% della produzione per la tenuta in depressione e a bassissime pressioni ne fa la valvola ideale per l'impiego in impianti industriali o comunque con fluidi aggressivi, purché compatibili con il PVC (vedere tabelle di resistenza chimica)
- Passaggio totale
- Possibilità di smontaggio radiale anche in presenza di pressione a monte della stessa

Dimensioni Dimensions

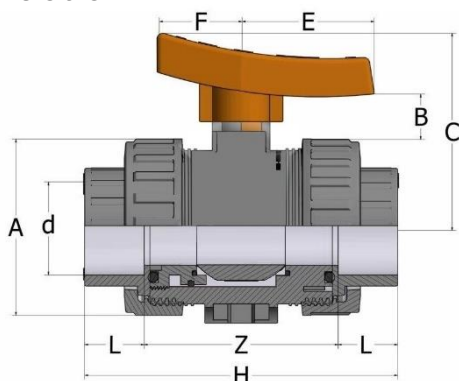

Characteristics

- 2-Way **industry series** ball valve with PVC body and metric series plain female sockets for solvent welding compliant EN ISO 1452 standard
- Size ranges from DN 10 mm up to DN 100 mm
- EPDM (standard) or FPM (on request) gaskets
- Maximum working pressure:
 - from DN 10 to DN 50: 16 bar with water at 20 °C
 - from DN 65 to DN 100: 10 bar with water at 20 °C
- Bidirectional
- Optimal handling (low torque)
- Each valve is tested in vacuum conditions and in extremely low pressure, then makes it the ideal valve to be used in industrial plant and with aggressive fluids (see table of chemical resistance)
- Full bore
- Possibility of radial taking apart also in presence of upstream pressure of the same one

d	DN	L	Z	H	A	B	C	E	F	PN	Peso Weight (g)
16	10	14	74	102	50	10	54	39	19	16	180
20	15	16	70	102	50	10	54	39	19	16	170
25	20	19	82	120	60	11	64	47	22	16	270
32	25	22	86	130	68	13	74	55	25	16	380
40	32	26	97	149	80	18	87	60	30	16	564
50	40	31	103	165	96	20	100	68	35	16	870
63	50	38	123	199	116	20	118	80	40	16	1514
75	65	44	130	218	145	25	150	90	45	10	2345
90	80	51	148	250	166	28	175	100	50	10	3690
110	100	61	168	290	210	28	200	120	60	10	6040



Ricambi
Spare parts

Pos.	Nr.	Componenti Components	Materiale Materials
1	1	Maniglia – <i>Handle</i>	PVC
2	1	Asta – <i>Stem</i>	PVC
3	1	Corpo – <i>Body</i>	PVC
4	2	Collare – <i>Union end</i>	PVC
5	2	Ghiera – <i>Union nut</i>	PVC
6	1	Sfera – <i>Ball</i>	PVC
7	1	Supporto filettato – <i>Threaded support</i>	PVC
8	2	Guarnizione sfera – <i>Ball seat</i>	PTFE
9	2	O-ring corpo – <i>O-ring union</i>	EPDM or FPM
10	1	O-ring supporto – <i>O-ring sealing bush</i>	EPDM or FPM
11	2	O-ring sfera – <i>O-ring ball seat</i>	EPDM or FPM
12	2	O-ring asta – <i>O-ring stem</i>	EPDM or FPM

