



VALVOLA MANUALE A FARFALLA MANUAL BUTTERFLY VALVE



Caratteristiche

- Valvola manuale a farfalla con corpo wafer per intercettazione e regolazione in esecuzione a stelo libero
- Corpo valvola in PP-GR resistente a pressioni di esercizio fino a 10 bar a 20 °C ed ai raggi UV
- Disco in PVC
- Tenuta intercambiabile con manicotto nei materiali EPDM, FKM
- Sistema di foratura ad asole ovali
- Lunette in ABS per facilitare l'autocentraggio di flange e bulloni
- Dimensioni di ingombro della valvola in accordo con ISO 5752 (DN 40÷200 Medium serie25, DN 250÷300 Long Serie16), DIN 3202 K2 e ISO 5752 (DN 65÷200 K2, DN 250÷300 K3)
- Versione speciale anulare Lug PN 10 a foratura completa DIN 2501 o ANSI B16.5 cl. 150 con inserti filettati in acciaio inossidabile AISI 316 affogati a caldo.

Dati tecnici

- La foratura del corpo valvola permette l'accoppiamento con dimensioni di foratura secondo le seguenti normative internazionali: DIN 2501, ISO DIS 9624, UNI 223, BS 10 table D/E, ASA B 16.5, class 150, JIS 2212 (K10 ad esclusione DN 200), JIS 2212 (K5 ad esclusione DN 50)

Dimensioni Dimensions

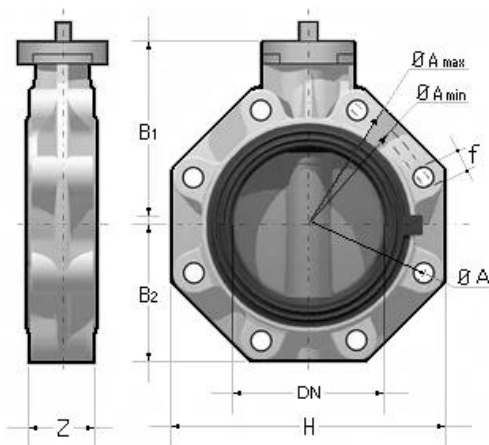

Characteristics

- Manual butterfly valve with wafer body used for fast control and ON/OFF operations without hand lever
- Body in GR-PP material resistant to working pressure up to 10 bar at 20 °C and UV rays
- PVC disk
- EPDM, FKM interchangeable primary liner
- Full flanged body with oval holes to fit with flanges in different standards
- Equipped with ABS insert to centre flanges and bolts
- Overall dimensions of the valve accordance with ISO 5752 (DN 40÷200 Medium Series 25, DN 250÷300 Long Series 16), DIN 3202 K2 and ISO 5752 (DN 65÷200 K2, DN 250÷300 K3)
- Special Lug version PN 10 fully drilled to DIN 2501 or ANSI B16.5 cl. 150 with moulded-in AISI 316 stainless steel threaded inserts.

Technical data

- Oval holes in the valve body allow connections to flanges with different drillings: DIN 2501, ISO DIS 9624, UNI 223, BS 10 table D/E, ASA B 16.5, class 150, JIS 2212 (K10 except for DN 200), JIS 2212 (K5 except for DN 50)

d	DN	PN	A min	A max	B ₁	B ₂	Z	H	f	Fori Holes	Peso Weight (g)
50	40	16	99	109	106	60	33	132	19	4	574
63	50	16	115	126	112	70	43	147	19	4	754
75	65	10	128	144	119	80	46	165	19	4	1000
90	80	10	145	160	133	93	49	185	19	12	1400
110	100	10	165	190	143	107	56	211	19	8	1750
125	125	10	204	215	167	120	64	240	23	8	2550
140	125	10	204	215	167	120	64	240	23	8	2550
160	150	10	230	242	180	134	70	268	23	8	3300
200	200	10	280	298	227	161	71	323	23	8	6000
225	200	10	280	298	227	161	71	323	23	8	6000



UNI -DIN

d	DN	PN	A	B ₁	B ₂	H	Z	f	Fori Holes	Peso Weight (Kg)
250	250	10	350	248	210	405	114	22	12	12
280	250	10	350	248	210	405	114	22	12	12
315	300	8	400	305	245	475	114	22	12	19
355	350	7	460	330	280	530	129	22	16	26
400	400	6	515	350	306	594	169	26	16	34

ANSI B16.5 cl. 150

d	DN	PN	A	B ₁	B ₂	H	Z	f	Fori Holes	Peso Weight (Kg)
10"	250	10	362	248	210	405	114	25,4	12	12
12"	300	8	432	305	245	475	114	25,4	12	19
14"	350	7	476	330	280	530	129	28,5	12	26
16"	400	6	540	350	306	594	169	28,5	16	34

Giunzioni

- Prima di effettuare l'installazione è opportuno verificare che il diametro di passaggio del collare consenta la corretta apertura della lente: in caso contrario è necessario smussare il collare
- I Ø 140 e Ø 225 da installarsi con collari adattatori speciali

Jointing

- *Before installing it's advisable to check that stubs thickness allows for correct opening of the disc: if not, it is necessary to chamfer the stub*
- *Ø 140 e Ø 225 to install with special adaptor stubs*